

MASTER PART MARK	VIN	AVAILABLE THICKNESS	YIELD MIN.	BLANK LENGTH	BLANK WIDTH	WEIGHT (LBS)
JCS04	E	N/A	N/A	N/A	N/A	4.09
SUB PART MARK	VIN	AVAILABLE THICKNESS	YIELD MIN.	BLANK LENGTH	BLANK WIDTH	WEIGHT (LBS)
PART-A	N/A	0.188	55	7.81	6.00	2.49
PART-B	N/A	0.188	55	5.00	6.00	1.60

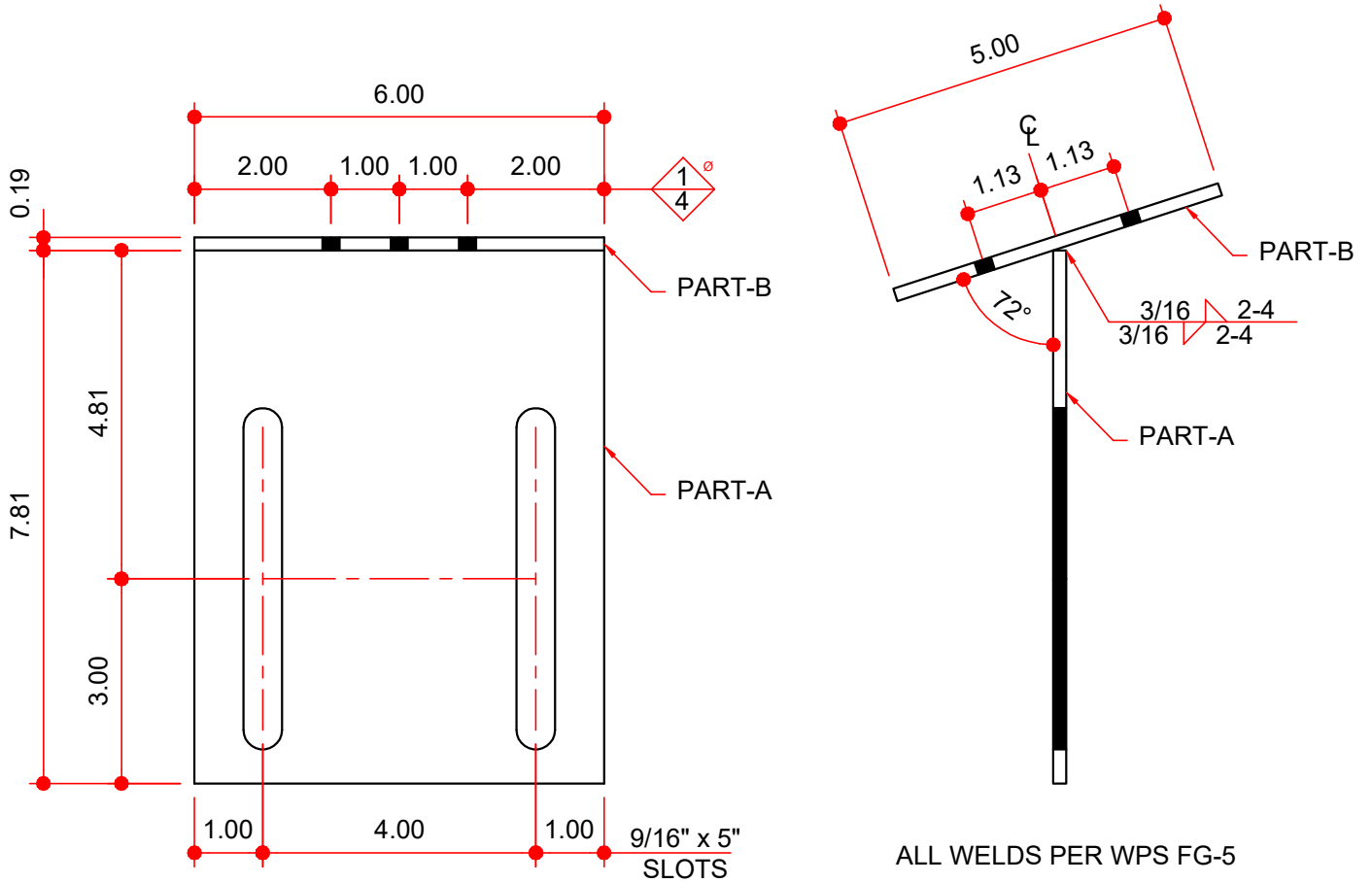

NOTES:

1)

AVAILABLE COLORS

GP, HD, RP