

MASTER PART MARK	VIN	AVAILABLE THICKNESS	YIELD MIN.	BLANK LENGTH	BLANK WIDTH	WEIGHT (LBS)
H5250	A	N/A	N/A	148.00	N/A	49.00

USED WITH THE FOLLOWING

SECONDARY SPACING:

- (3) 4'-0" SPACES
- (4) 3'-0" SPACES
- (6) 2'-0" SPACES

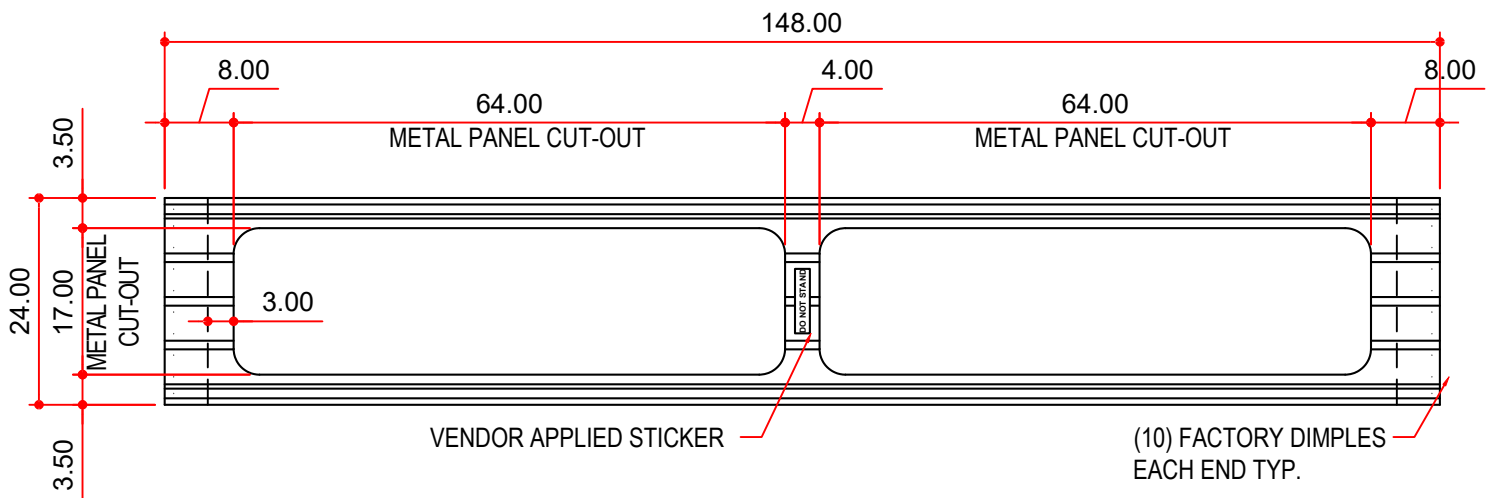

NOTES: BUYOUT

- 1) THIS UNIT **DOES NOT** HAVE A UL90 RATING & FLORIDA APPROVAL.
- 2) A PURCHASE REQUEST MAY BE REQUIRED FOR THIS PART. CHECK WITH YOUR PURCHASING DEPARTMENT.

AVAILABLE COLORS

PW ONLY