

MASTER PART MARK	VIN	AVAILABLE THICKNESS	YIELD MIN.	BLANK LENGTH	BLANK WIDTH	WEIGHT (LBS)
H5230	A	N/A	N/A	136.00	N/A	44.71

USED WITH THE FOLLOWING
SECONDARY SPACING:
(2) 5'-6" SPACES

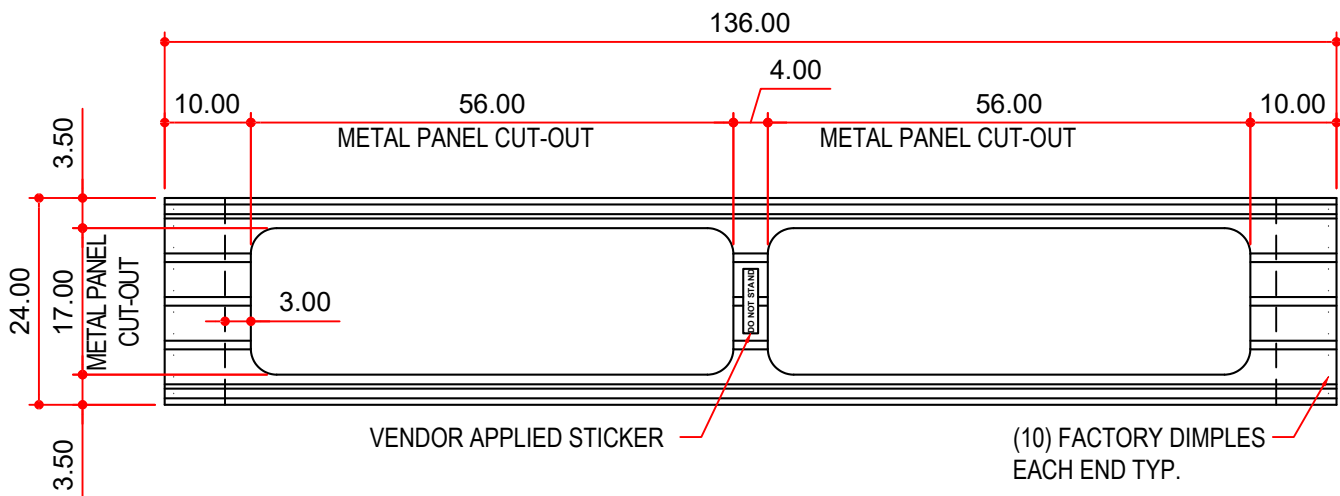

NOTES: BUYOUT

- 1) THIS UNIT **DOES NOT** HAVE A UL90 RATING & FLORIDA APPROVAL.
- 2) A PURCHASE REQUEST MAY BE REQUIRED FOR THIS PART. CHECK WITH YOUR PURCHASING DEPARTMENT.

AVAILABLE COLORS

PW ONLY