

MASTER PART MARK	VIN	AVAILABLE THICKNESS	YIELD MIN.	BLANK LENGTH	BLANK WIDTH	WEIGHT (LBS)
H5220	A	N/A	N/A	136.00	N/A	47.71

**USED WITH THE FOLLOWING**  
**SECONDARY SPACING:**  
(2) 5'-6" SPACES

**NOTE:**  
INSULATED TRANSLUCENT  
PANELS UTILIZE DOUBLE LAYER  
OF FIBERGLASS PANEL

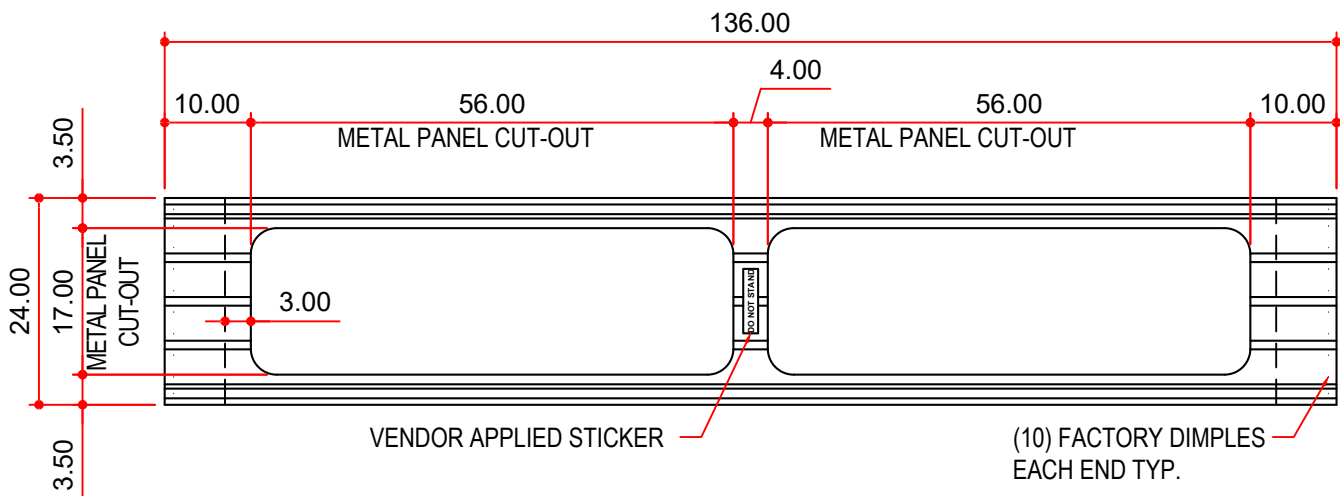

**NOTES: BUYOUT**

- 1) THIS UNIT **DOES NOT** HAVE A UL90 RATING & FLORIDA APPROVAL.
- 2) A PURCHASE REQUEST MAY BE REQUIRED FOR THIS PART. CHECK WITH YOUR PURCHASING DEPARTMENT.

**AVAILABLE COLORS**

PW ONLY