

MASTER PART MARK	VIN	AVAILABLE THICKNESS	YIELD MIN.	BLANK LENGTH	BLANK WIDTH	WEIGHT (LBS)
H2720	A	N/A	50 KSI	N/A	N/A	0.58
H2730	A	N/A	50 KSI	N/A	N/A	0.66
H2740	A	N/A	50 KSI	N/A	N/A	0.79
H2750	A	N/A	50 KSI	N/A	N/A	0.91
H2760	A	N/A	50 KSI	N/A	N/A	1.08
H2770	A	N/A	50 KSI	N/A	N/A	1.26

**MATERIAL:**

CLIP TAB: G-90 GALVANIZED STEEL (PER ASTM A-653) 50 KSI MIN YLD. 0.037 THICK

CLIP BASE: G-90 GALVANIZED STEEL (PER ASTM A-653) 50 KSI MIN YLD. 0.064 THICK

MK #	CLIP TYPE	STAND OFF	DIM "A"	DIM "B"	DIM "C"
H2720	SHORT	1/2"	3.41	3.6	8.00
H2740	SHORT	1/2"	3.41	3.6	12.00
H2760	SHORT	1/2"	3.41	3.6	16.00
H2730	TALL	1 1/2"	4.41	4.6	8.00
H2750	TALL	1 1/2"	4.41	4.6	12.00
H2770	TALL	1 1/2"	4.41	4.6	16.00

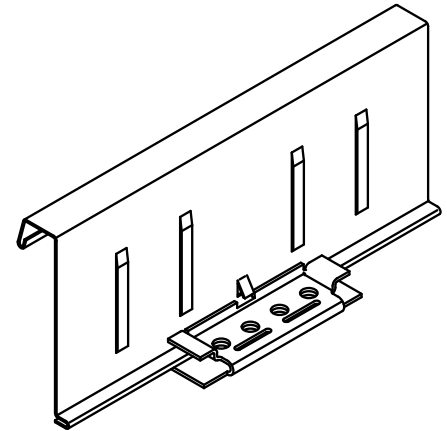

**ASSEMBLED ISOMETRIC**

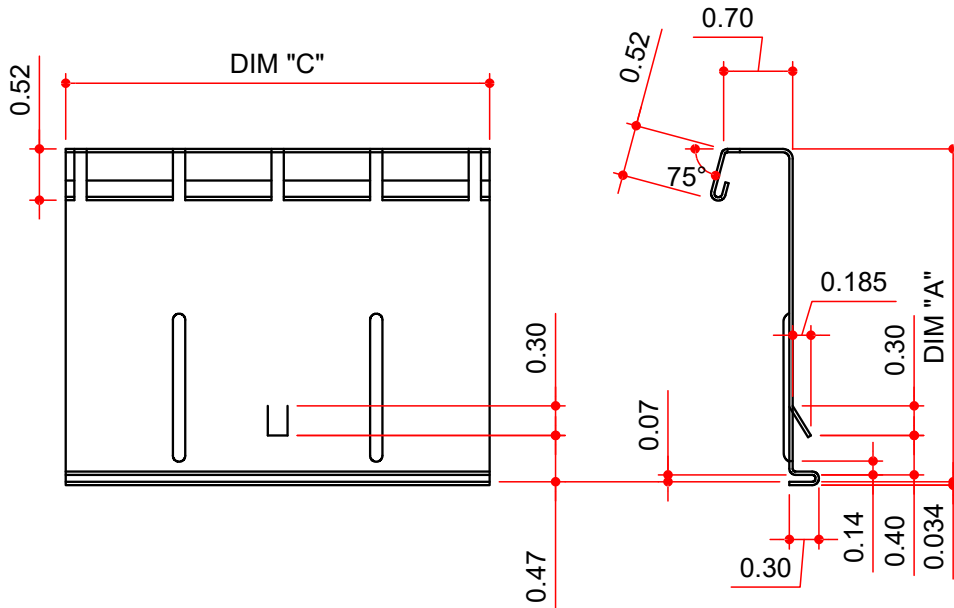

**CLIP TAB FRONT VIEW**

**CLIP TAB END VIEW**

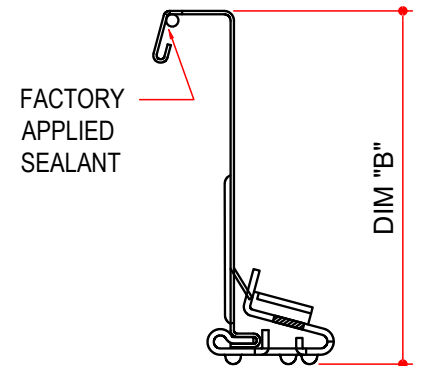

**ASSEMBLED END VIEW**

**NOTES: BUYOUT**

- 1) PERIMETER CLIPS ARE ONLY OFFERED IN SHORT AND TALL.
- 2) CLIP TAB TO BASE ASSEMBLY IS A SLIDING FIT. MAX RESISTANCE 50LB OF FORCE TO CAUSE THE CLIP TAB TO SLIDE INSIDE THE BASE WHEN INSTALLED.

**AVAILABLE COLORS**

NP