

MASTER PART MARK	VIN	AVAILABLE THICKNESS	YIELD MIN.	BLANK LENGTH	BLANK WIDTH	WEIGHT (LBS)
GSA121	A	24 OR 26 GA	33 KSI	121.00	25.69	17.17
GSA242 <sup>2</sup>	A	24 OR 26 GA	33 KSI	242.00	25.69	34.34

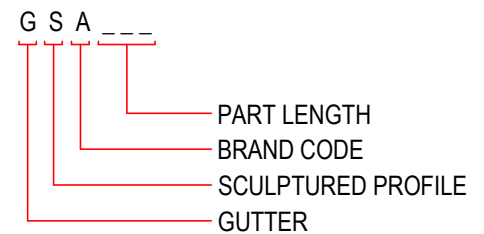
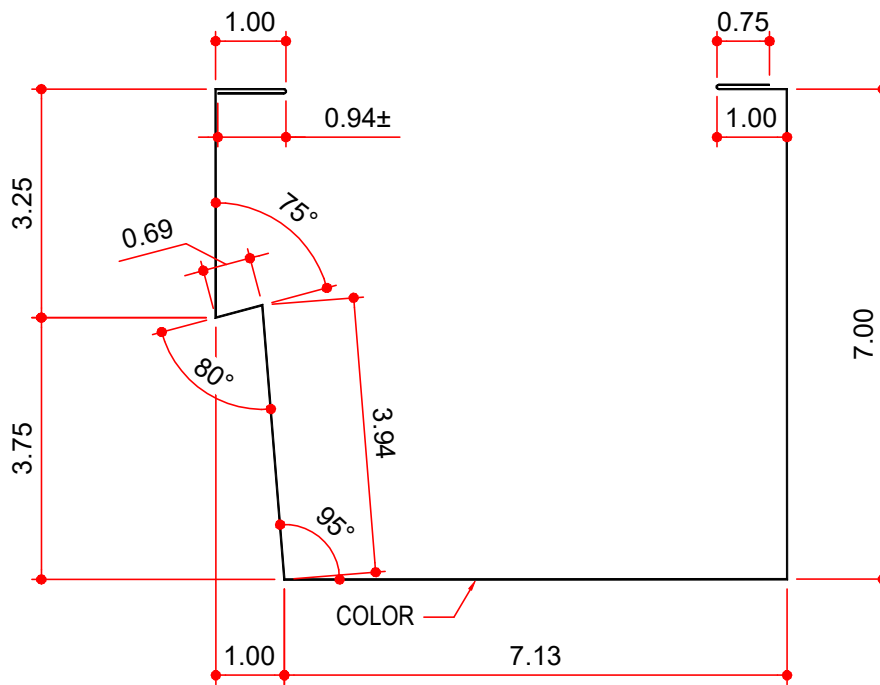

**NOTES:**

- 1) ALL BENDS ARE 90° UNO
- 2) NOT AVAILABLE FOR UTAH PRODUCTION

**AVAILABLE COLORS**  
ALL STANDARD SMP  
& PVDF COLORS