

MASTER PART MARK	VIN	AVAILABLE THICKNESS	YIELD MIN.	BLANK LENGTH	BLANK WIDTH	WEIGHT (LBS)
GCB08	B	N/A	N/A	N/A	N/A	2.77
SUB PART MARK	VIN	AVAILABLE THICKNESS	YIELD MIN.	BLANK LENGTH	BLANK WIDTH	WEIGHT (LBS)
PART-A	N/A	0.150	55 KSI	10.00	5.00	2.12
PART-B	N/A	0.150	55 KSI	2.25	6.75	0.65

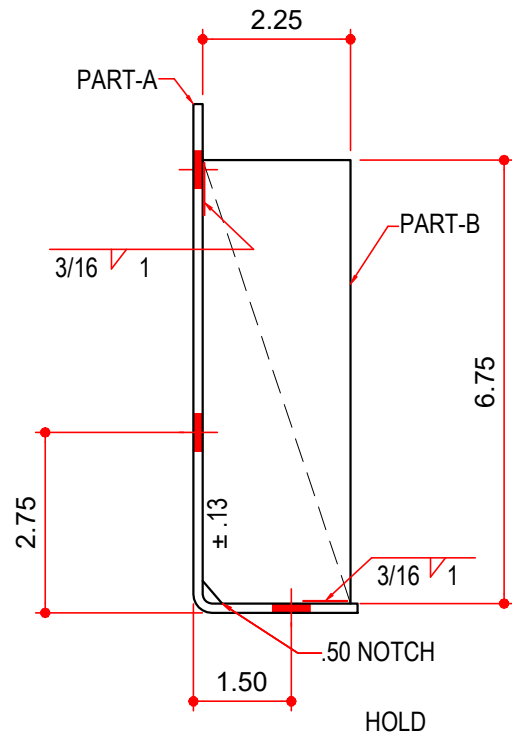
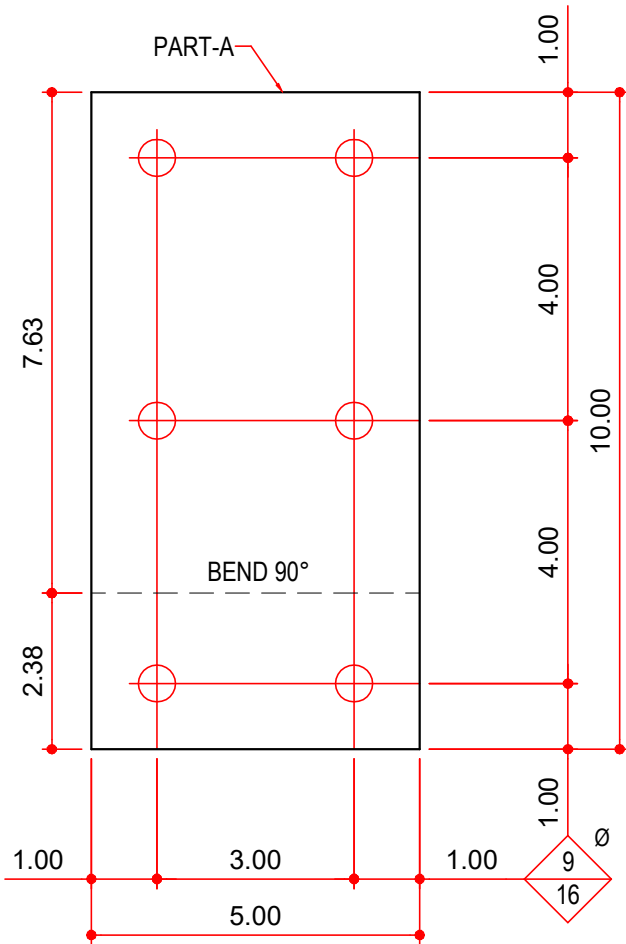

NOTES:

- 1) ALL WELD PER AWS STANDARDS.
- 2) GUSSET INFORMATION NOTE:
 - A) FULL GUSSET IS THE STANDARD
 - B) ALTERNATE OPTION TO PROVIDE A HALF GUSSET IS ACCEPTABLE BY DESIGN.
- 3) GUSSET PLATE TOLERNCES:
 - A) WIDTH (+0.0, -0.25)
 - B) LENGTH: 6.75 (+0.50, -0.50)

AVAILABLE COLORS

GP, HD, RP