

MASTER PART MARK	VIN	AVAILABLE THICKNESS	YIELD MIN.	BLANK LENGTH	BLANK WIDTH	WEIGHT
FBC__	A	0.105	55	BELOW	4.875	BELOW

MASTER PART MARK	BLANK LENGTH	TOTAL WEIGHT LBS	MASTER PART MARK	BLANK LENGTH	TOTAL WEIGHT LBS	MASTER PART MARK	BLANK LENGTH	TOTAL WEIGHT LBS
FBC14	14.00	2.03	FBC36	36.00	5.22	FBC58	58.00	8.41
FBC16	16.00	2.32	FBC38	38.00	5.51	FBC60	60.00	8.70
FBC18	18.00	2.61	FBC40	40.00	5.80	FBC62	62.00	8.99
FBC20	20.00	2.90	FBC42	42.00	6.09	FBC64	64.00	9.28
FBC22	22.00	3.19	FBC44	44.00	6.38	FBC66	66.00	9.57
FBC24	24.00	3.48	FBC46	46.00	6.67	FBC68	68.00	9.86
FBC26	26.00	3.77	FBC48	48.00	6.96	FBC70	70.00	10.15
FBC28	28.00	4.06	FBC50	50.00	7.25	FBC72	72.00	10.44
FBC30	30.00	4.35	FBC52	52.00	7.54	FBC74	74.00	10.73
FBC32	32.00	4.64	FBC54	54.00	7.83			
FBC34	34.00	4.93	FBC56	56.00	8.12			

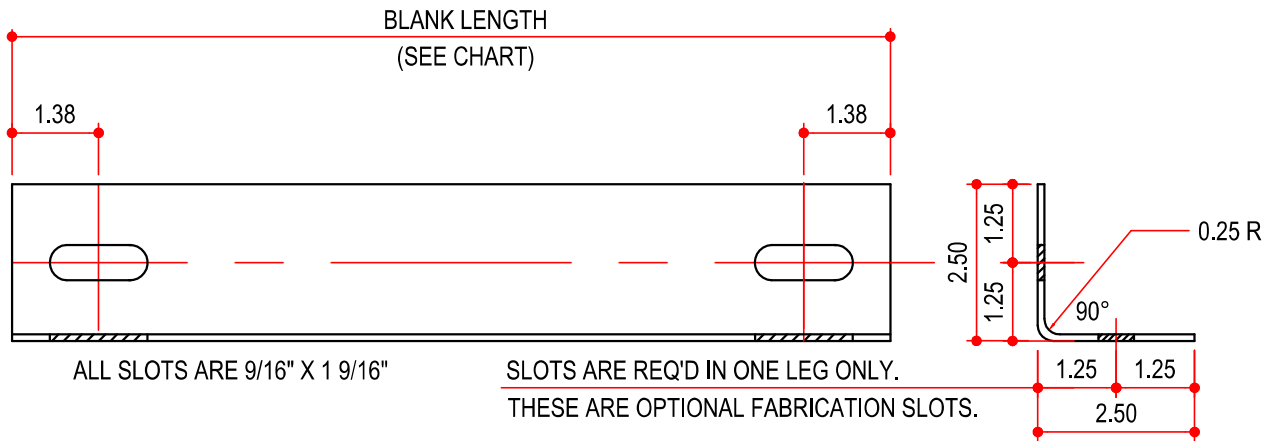

NOTES:  
N/A

AVAILABLE COLORS

GP, GZ, RP