

MASTER PART MARK	VIN	AVAILABLE THICKNESS	YIELD MIN.	BLANK LENGTH	BLANK WIDTH	WEIGHT (LBS)
GCM01	D	NA	NA	NA	NA	2.70
SUB PART MARK	VIN	AVAILABLE THICKNESS	YIELD MIN.	BLANK LENGTH	BLANK WIDTH	WEIGHT (LBS)
PART-A	D	0.150	55KSI	10.000	5.000	2.13
PART-B	D	0.150	55KSI	2.250	6.000	0.57

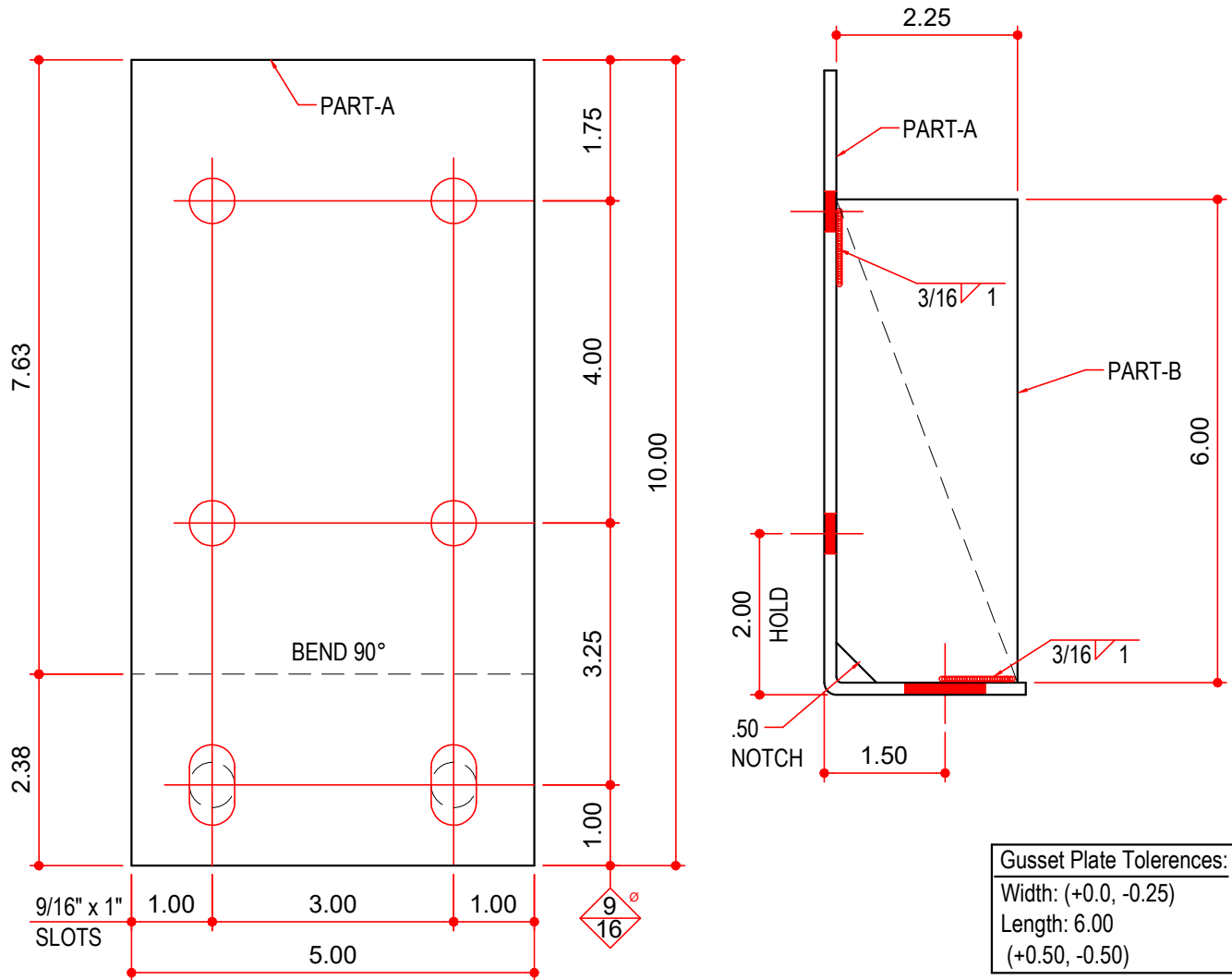

**NOTES:**

- 1) DUE TO LIMITED PRODUCTION CAPABILITIES THE TERRELL PLANT WILL PRODUCE THIS CLIP WITH ALL 9/16"Ø HOLES.
- 2) FULL GUSSET STANDARD. ALTERNATE TO PROVIDE A HALF GUSSET IS ACCEPTABLE BY DESIGN
- 3) ALL WELDS PER WPS FG-5

**AVAILABLE COLORS**

GP, HD, RP, NP