

MASTER PART MARK	VIN	AVAILABLE THICKNESS	YIELD MIN.	BLANK LENGTH	BLANK WIDTH	WEIGHT (LBS)
CAP02- <u>  </u>	C	0.250 Ø	N/A	VARIES	N/A	VARIES
SUB PART MARK	VIN	AVAILABLE THICKNESS	YIELD MIN.	BLANK LENGTH	BLANK WIDTH	WEIGHT (LBS)
CBL01	N/A	0.250 Ø	N/A	N/A	N/A	N/A
(2) H0520	N/A	0.875 Ø	N/A	N/A	N/A	N/A
(2) H9100	N/A	0.250 Ø	N/A	N/A	N/A	N/A
SUB01	N/A	0.150 MINIMUM	50 KSI	12.00	4.00	3.40

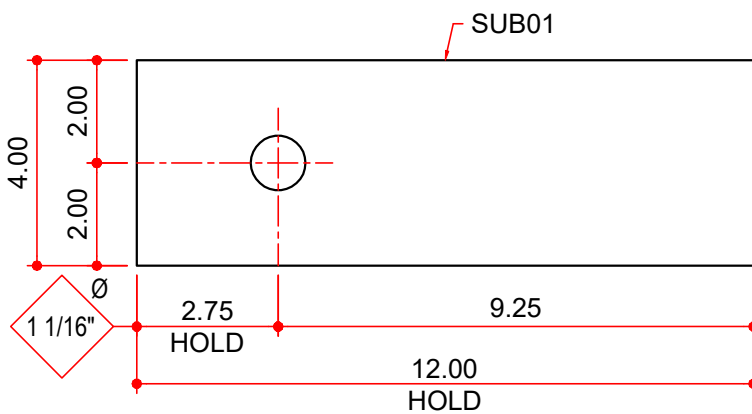

**PART DESCRIPTION**

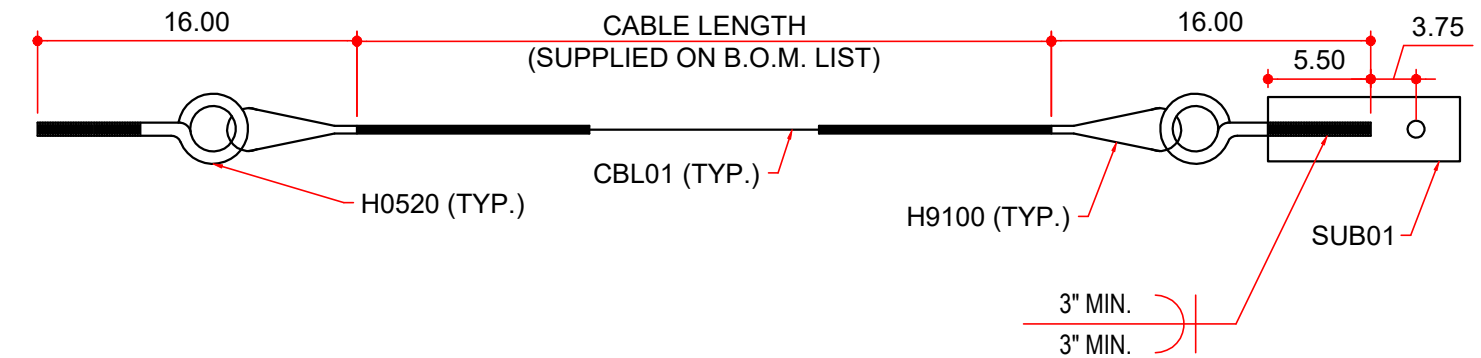
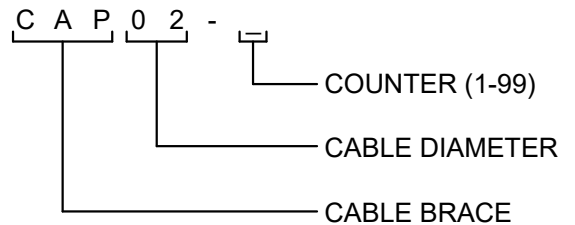

**NOTES:**

- 1) SUB01 CAN BE MADE FROM WEB SCRAP/COIL.
- 2) ALL WELDS PER AWS STANDARDS.

**AVAILABLE COLORS**

- CBL01 - GZ
- H0520 - GZ
- H9100 - GZ
- SUB01 - GP,HD,RP